

# Hybrid Stepper Motor 60BYGH450D-03

## Mechanical Dimensions:

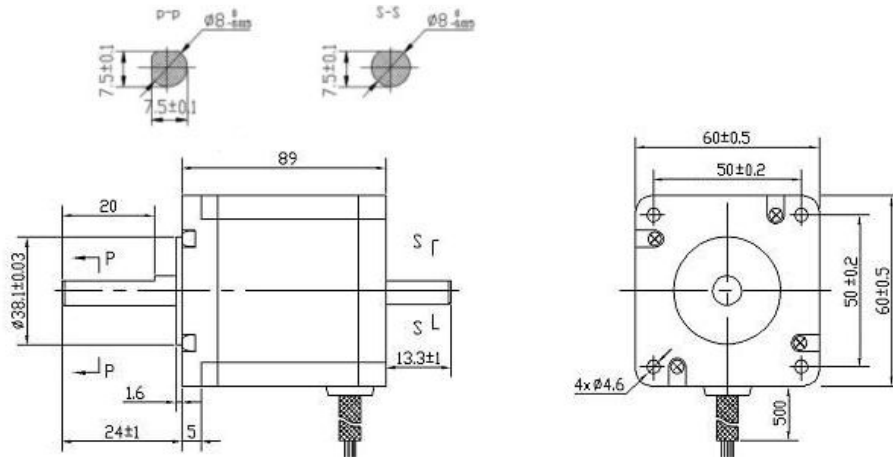

Test conditions:  
 Stepper motor driver: Leadshine AM882  
 Connection: Bipolar parallel  
 Stepping mode: Full step

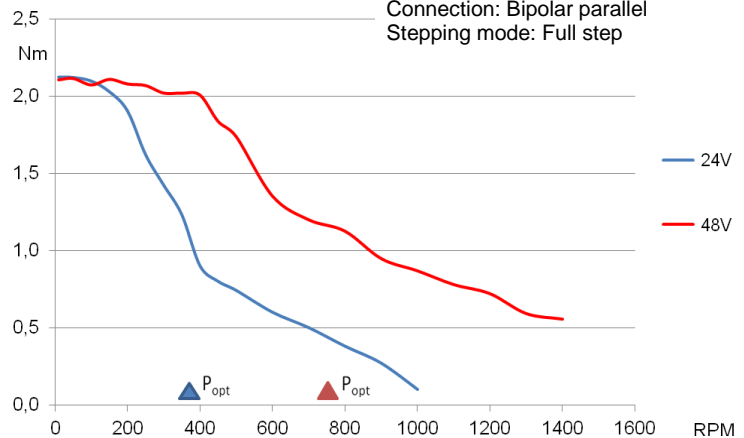
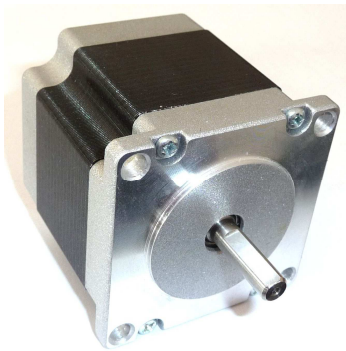

## Electrical Specifications:

	Unipolar	Bipolar Serial	Bipolar Parallel
No. of phases	4	2	2
Step Angle	1.8 ± 0.09°		
Rated Voltage (V)	4.38	6.13	3.07
Current (A)	3.0	2.1	4.2
Resistance (Ω)	1.46	2.92	0.73
Inductance (mH)	3.3	13	3.3
Holding Torque coils on DC (Nm)	2.4	3.3	3.3
Holding Torque step mode (Nm)	1.7	2.3	2.3
Rotor Inertia (gcm <sup>2</sup> )	840		
Insulation Class	B		
Insulation Resistance	100 MΩ, 500 V DC		
Weight (kg)	1.5		