

EM556S

Stepper Motor Driver



Digital Driver Model EM556S

Digital Technology, max. 50 VDC/ 5.6 A



Product Description:

The EM556S is a new versatile, digital stepper drive based on Leadshine's widely implemented DM stepper drives (10 millions + units in the field). While retaining features of simple design, easy setup, high precision and reliability, Leadshine has also upgraded it by adopting the latest stepper control technology and added additional advanced features for better torque (10 - 25 %), quicker response time, control command smoothing, easy self-test, etc.

The EM556S is able to power 2 phase and 4 phase stepper motors smoothly with very low motor heating & noise. It can take +20 up to +50 VDC supply voltage and output 0.5 to 5.6 A current. All the micro step and output current configurations can be easily done via built in DIP switches. Its control type (step & direction or CW/ CCW) and command smooth filtering can also be configured via DIP switches. Therefore, the EM556S is an ideal choice for many applications requiring simple step & direction or CW/ CCW control of NEMA 17, NEMA 23 and NEMA 24 stepper motors.

Features:

- Anti-Resonance for optimal torque, extra smooth motion, low motor heating and noise
- Supply voltage +20 - +50 VDC
- Output current of 1.8 - 5.6 A via DIP Switches, or 0.5 - 5.6 A via software (increase of 0.1 A)
- Idle current reduction to 50 % or 90 % selection via SW4 to reduce motor heat
- Motor self-test and parameter auto-setup technology, offers optimum responses with different motors
- Step & direction (PUL/ DIR) or CW/ CCW (double pulse) control
- Pulse input frequency up to 200 kHz (500 kHz optional)
- Configurable control command smoothing for reducing motor vibration
- Microstep resolution of 16 setting of 200 - 25,600 via DIP switches, or 200 - 51,200 via software (increments of 200)
- Convenient self-test for easy diagnosis
- Smooth motor start-up without "jump"
- Fault and motor brake command output signal
- Over-voltage, over-current and motor cable error protections

Electrical Specifications:

Parameters	Min	Typ.	Max	Unit
Output current	0.5	-	5.6 (4.0 RMS)	A
Supply voltage	+20	24 - 48	+50	VDC
Logic signal current	7	10	16	mA
Pulse input frequency	0	-	200	kHz
Insulation resistance	500			MΩ

Further Specifications:

Parameters	Min	Typ.	Max
Microsteps/ 1,8°	Full-step		25,600 (51,200*)
Pulse/ Direction (PUL/ DIR)		X	
Double pulse (CW/ CCW)		X	
NEMA sizes	17		24
Motor type Mecheltron	42BYGH-XXX		60BYGH-XXX

*via software

EM556S

Stepper Motor Driver



Digital Driver
Model EM556S

Mechanical Specifications:

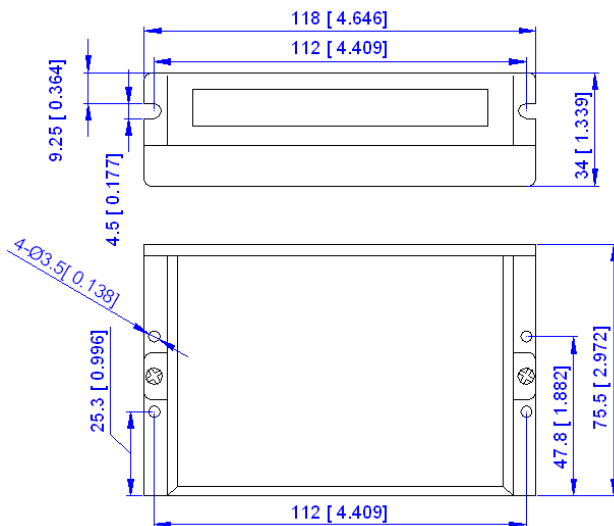

Unit: mm [inch]

Applications:

The EM556S stepper driver is designed to power 2 phase or 4-phase NEMA 17, 23 and 24 hybrid stepper motors. It can be adopted in many industries (CNC machinery, electronics, medical, automation, packaging...) for applications such as CNC routers, mills, plasma, laser cutters, factory assembly lines, vending machines, etc. Its excellent performance, simple design, and easy setup features make EM556S ideal for many step & direction control type of applications such as X-Y tables, engraving machines, labelling machines, laser cutters, pick & place devices, and so on. Particularly it is well suited for applications where low noise levels, less heat development, high speed and high precision are desired.

Typical Connection Schematic:

A typical system consists of stepper motor, stepper motor driver, power supply and controller. The following image shows a typical connection schematic:

