

# HYBRID SERVO DRIVER ES-DH2306



## FEATURES:

- Closed-loop, eliminates loss of steps or movement synchronization
- Operating voltage: 150 - 230 VAC or 212 - 325 VDC
- Excellent response time, quick acceleration, and very high high-speed torque (30% more as open-loop)
- Load based output current of 0.5 - 6.0 A (PEAK)
- Significantly reduced motor heating and more efficiency
- Smooth motor motion and low motor noise
- Does not need a high torque margin
- No tuning for plug and play setup, and always stable
- Fast response, no delay and almost no settle time
- High torque at starting and low speed, high stiffness at standstill
- On-board LED panel for custom configuration and motion mode display
- Over voltage, over-current, and position-error protection
- Lower cost

The ES series offers an alternative for applications requiring high performance and high reliability when the servo was the only choice, while it remains cost-effective. The system includes a 3-phase stepper motor combined with a fully digital, high performance drive and an internal encoder which is used to close the position, velocity and current loops in real time, just like servo systems. It combines the best of servo and stepper motor technologies, and delivers unique capabilities and enhancements over both, while at a fraction of the cost of a servo system.

## GENERAL SPECIFICATIONS:

### Electrical Specifications ( $T_j = 25^{\circ}\text{C}/77^{\circ}\text{F}$ )

Parameters	ES-DH2306			
	Min	Typical	Max	Unit
Output current (PEAK)	0.5	-	6.0	A
Input voltage	150 (212)	180 (255)	230 (325)	VAC (VDC)
Logic signal current	7	13	20	mA
Pulse input frequency	0	-	200	kHz
Microstep resolution	200		51200	Steps per rev.
Isolation resistance	500			MΩ

## CONNECTOR CONFIGURATION:

The ES-DH2306 has five connectors, each one for control signals connections, for encoder feedback, for main power supply and external braking resistor, control power supply and motor connection, and for RS232 communication.

# HYBRID SERVO DRIVER ES-DH2306

## Control Signal Connector – D-Sub, 44 pins, female

Pin	Name	I/O	Description
1 - 2			not connected
3	PUL+	I	<u>Pulse signal:</u> In single pulse (pulse/direction) mode, this input represents pulse signal, each rising or falling edge active (software configurable, see hybrid servo software operational manual for more detail); In double pulse mode (software configurable), this input represents clockwise (CW) pulse, active both at high level and low level. 4-5V when PUL-HIGH, 0-0.5V when PUL-LOW. For reliable response, pulse width should be longer than 10µs. Series connect resistors for current-limiting when +12V or +24V used. The same as DIR and ENA signal.
4	PUL-	I	
5	DIR+	I	<u>Direction Signal:</u> In single-pulse mode, this signal has low/high voltage levels, representing two directions of motor rotation. In double-pulse mode (software configurable), this signal is counter-clock (CCW) pulse, active both at high level and low level. For reliable motion response, DIR signal should be ahead of PUL signal by 5µs at least. 4-5V when DIR-HIGH, 0-0.5V when DIR-LOW. Please note that rotation direction is also related to motor-driver wiring match. Exchanging the connection of two wires for a coil to the driver will reverse motion direction. The direction signal's polarity is software configurable.
6	DIR-	I	
7	ALM+		<u>Alarm Signal:</u> OC output signal, active when one of the following protection is activated: over-voltage, over current, braking error and position following error. This port can sink or source max. 100mA current at 5V. The active level of alarm signal is software configurable.
8	ALM-		
9 - 10			not connected
11	ENA+	I	<u>Enable signal:</u> This signal is used for enabling/disabling the driver. By default, high level for enabling the driver and low level for disabling the driver (@ NPN control signal). It's usually left <b>UNCONNECTED (ENABLED)</b> . Please note that PNP and Differential control signals are on the contrary, namely low level for enabling. The active level of ENA signal is software configurable.
12	ENA-	I	
13 - 44			not connected

## Encoder Feedback Connector

Pin	Name	I/O	Description
1	EA+	I	Encoder channel A+ input
2	EB+	I	Encoder channel B+ input
3	EGD	GND	Signal ground
4	HW	I	Reserved
5	HU	I	Reserved
6	FG	GND	Ground terminal for shield
7	EZ+	I	Reserved

# HYBRID SERVO DRIVER ES-DH2306

8	EZ-	I	Reserved
9	HV	I	Reserved
10	NC	-	Not Connected
11	EA-	I	Encoder channel A- input
12	EB-	I	Encoder channel B- input
13	VCC	O	+5V @ 100 mA max.
14	NC	-	Not Connected
15	NC	-	Not Connected

## Connector for main power supply and external brake resistor

Pin	Name	I/O	Description
1	L	I	Main power supply input connected to 150 – 230 VAC
2	N	I	
3	NC	-	
4	BR1	I	External brake resistor (optional, value: 100 Ω to 120 Ω, 100 W)
5	P+	O	Internal DC bus voltage output. The brake resistor is connected between BR1 and P+.

## Control Power and Motor Connector

Pin	Name	I/O	Description
1	U	O	Motor Phase U
2	V	O	Motor Phase V
3	W	O	Motor Phase W
4	PE	-	Case ground
5	L	I	Control power supply input 150 – 230 VAC
6	N	I	

## RS232 Communication Port

Pin	Name	I/O	Description
1	GND	GND	Ground
2	TxD	O	RS232 transmit.
3	+5V	O	Reserved +5V power output (Note: Do not connect it to RS232 port)
4	RxD	O	RS232 receive.
5	NC	-	Not connected.
6	NC	-	Not connected.

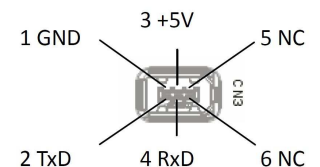

## TYPICAL CONNECTIONS:

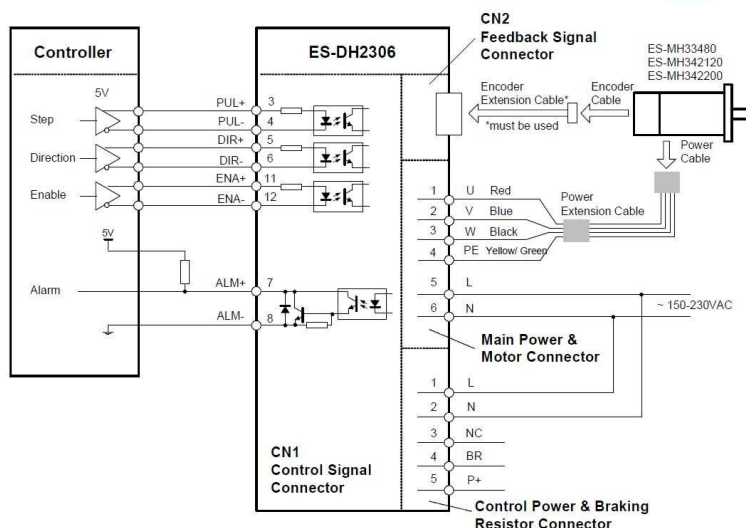

Connection to controller with differential output (differential control signal)

# HYBRID SERVO DRIVER ES-DH2306

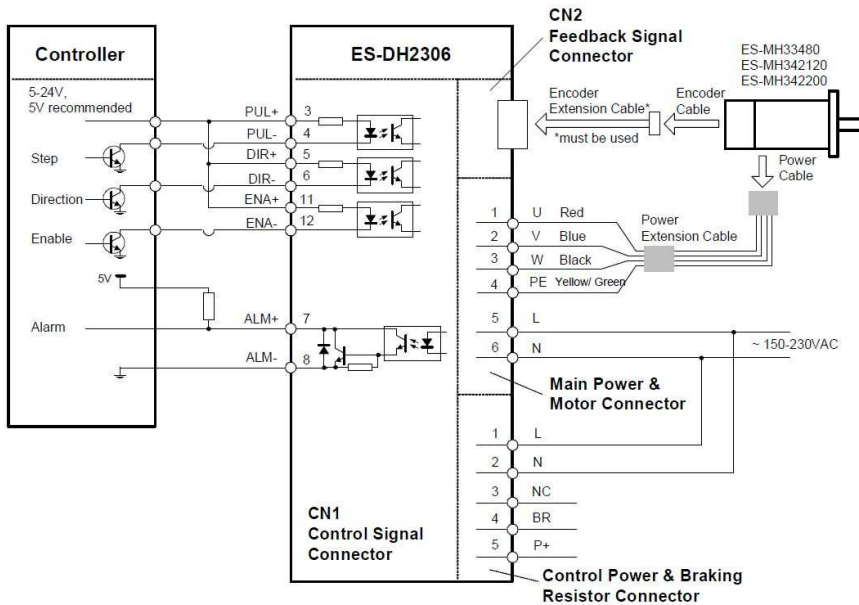

Connection to controller with sinking output (NPN control signal)

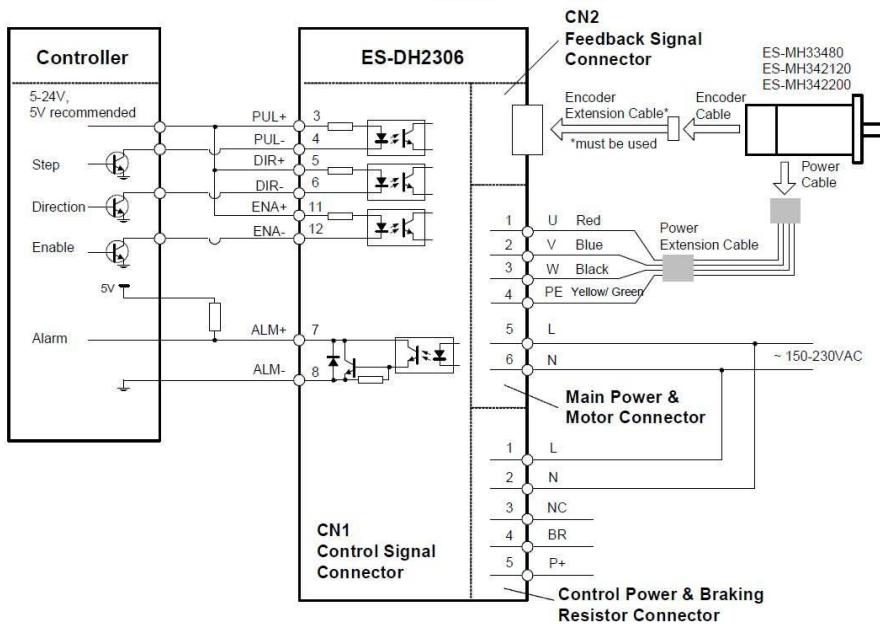

Connection to controller with sourcing output (PNP control signal)

# HYBRID SERVO DRIVER ES-DH2306

MECHANICAL SPECIFIKATION (unit: mm):

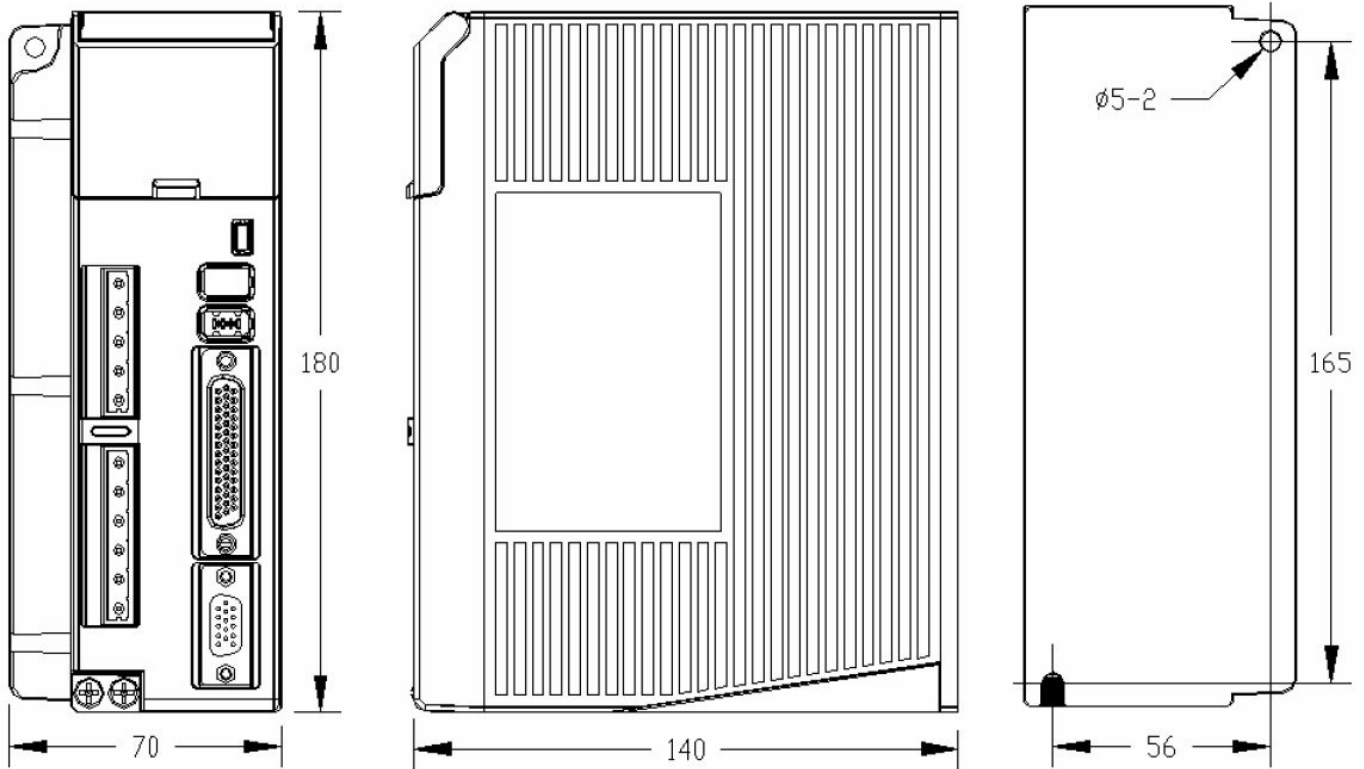

03.04.17